



**GRADCO SA**  
PERFECTION IN PLASTIC PIPING & ENGINEERING

# COMPANY PROFILE & TECHNICAL CATALOGUE

[www.gradcosa.co.za](http://www.gradcosa.co.za)



[www.gradcosa.co.za](http://www.gradcosa.co.za)



[www.gradcosa.co.za](http://www.gradcosa.co.za)

# INDEX

<b>ABOUT US</b>	<b>01</b>
<b>FEATURES &amp; BENEFITS</b>	<b>02</b>
<b>HDPE PIPE APPLICATIONS</b>	<b>03</b>
<b>SANS 4427-2:2019 PIPE CHART</b>	<b>04</b>
<b>DESIGN CONSIDERATION</b>	<b>06</b>
<b>FITTINGS</b>	<b>08</b>
<b>INJECTION MOULDED FITTINGS</b>	<b>12</b>
<b>FLANGES</b>	<b>17</b>
<b>QUALITY CONTROL</b>	<b>20</b>
<b>CERTIFICATIONS &amp; APPROVALS</b>	<b>21</b>





## ABOUT

Gradco SA (PTY) LTD presents itself as a leading brand in the HDPE piping industry. We specialize in the manufacturing, supplying and installation of HDPE pipes and fittings.

We are a B-BBEE Level 3 company with 51% black ownership.

To enable us to be a dependable brand, we have world class facilities like:

- Modern well-equipped factory
- Testing Laboratory
- State of the art Technology
- Sourced Suppliers
- Qualified workers

Our world-class extrusion facility is capable of producing in excess of 1000 tons per month. Our facility also includes a fully equipped laboratory and pressure testing baths, enabling us to continually test and regulate our piping to conform to the highest standard in the industry.

We also offer extended services like:

- Manufacturing
- Product Supply
- Installation
- Maintenance
- Pumps & Valves





FEATURE	BENEFITS
High Flexibility combined with high impact resistance	Can be supplied as coils of up to 110mm (external pipe diameter). Coils reduce the number of joints and stress to the site. Under the same conditions, PE pipe develops much lower sure pressure than rigid pipes. Unaffected by soil settlement. High tenacity and anti-impact intensity. Excellent resistance against inappropriate handling with low notch sensitivity and high tear resistance.
Squeeze-off ability	With no damage to or effect on the pipe's short & long term properties.
UV Resistance	With no damage to or effect on the pipe's short & long term properties.
High chemical and corrosion resistance	Does not rust or corrode scaling and corrosion by electrolytic actions. Lower life cycle cost, long life expectancy. Very low maintenance. Withstands aggressive soil conditions, ground water. Suitable for use with a broad range of chemicals. Resistance to all natural gas constituents.
Non-toxic material	Approved for use in drinking water applications. Approved for food contact.
Abrasion resistance	HDPE pipes outperform conventional pipes, depending on the application, by factor of 7.
Low thermal conductivity	Thermal conductivity value of 0,4 W/m °C
Excellent flow characteristics	Polyolefin pipes have a hydraulically smooth bore. In the Colebrook formula K is equal to 0,001; in the Hazen-Williams formula C is equal to 155.

# HDPE PIPE APPLICATIONS

Polyolefin piping systems are used in many applications such as:

- Hot & cold water systems
- Drinking potable water supply
- Irrigation
- Storm water draining
- Land draining
- Draining of leachate systems
- Industrial water
- Chemical process piping
- Firefighting systems
- Domestic gas & oil pipe systems
- Water disposal
- Sewer Network
- Sewer & effluent treatment plants
- Outfalls
- Waste dump
- Industrial waste
- Sand & slurry pumping
- Cable duct (non-pressure pipes)



# SANS 4427-2:2019 (PIPE CHART)

DIAMETER		OVALITY	PN 4 SDR 41		0.960	PN 5 SDR 33		0.960	PN 6.3 SDR 26		0.960	PN 8 SDR 21		0.960	PN 10 SDR 17		0.960	DIAMETER		OVALITY
MIN	MAX	MAX	MIN	MAX	KG/M	MIN	MAX	KG/M	MIN	MAX	KG/M	MIN	MAX	KG/M	MIN	MAX	KG/M	MIN	MAX	MAX
110	110.7	2.2	2.7	2.9	0.91	3.3	3.35	1.07	4.2	4.8	1.43	5.3	6	1.78	6.6	7.4	2.17	110	110.7	2.2
125	125.8	2.5	3	3.25	1.15	3.8	4.1	1.44	4.8	5.4	1.84	6	6.7	2.27	7.4	8.3	2.77	125	125.8	2.5
140	140.9	2.8	3.4	3.65	1.45	4.2	4.55	1.78	5.4	6.1	2.33	6.7	7.5	2.85	8.3	9.3	3.48	140	140.9	2.8
160	161	3.2	3.9	4.15	1.89	4.8	5	2.29	6.2	7	3.05	7.7	8.6	3.73	9.5	10.6	4.54	160	161	3.2
180	181.1	3.6	4.4	4.65	2.39	5.5	5.8	2.97	6.9	7.7	3.80	8.6	9.6	4.69	10.7	11.9	5.75	180	181.1	3.6
200	201.2	4	4.9	5.2	2.96	6.1	6.45	3.66	7.7	8.6	4.72	9.6	10.7	5.81	11.9	13.2	7.09	200	201.2	4
225	226.4	4.5	5.5	5.8	3.73	6.8	7.2	4.60	8.6	9.6	5.93	10.8	12	7.34	13.4	14.9	9.00	225	226.4	4.5
250	251.5	5	6.1	6.45	4.61	7.6	8	5.69	9.6	10.7	7.34	11.9	13.2	8.99	14.8	16.4	11.03	250	251.5	5
280	281.7	9.8	6.8	7.2	5.76	8.5	9	7.15	10.7	11.9	9.16	13.4	14.9	11.35	16.6	18.4	13.85	280	281.7	9.8
315	316.9	11.1	7.7	8.6	7.54	9.7	10.8	9.42	12.1	13.5	11.67	15	16.6	14.26	18.7	20.7	17.54	315	316.9	11.1
355	357.2	12.5	8.7	9.7	9.59	10.9	12.1	11.91	13.6	15.1	14.74	16.9	18.7	18.10	21.1	23.4	22.33	355	357.2	12.5
400	402.4	14	9.8	10.9	12.16	12.3	13.7	15.17	15.3	17	18.70	19.1	21.2	23.08	23.7	26.2	28.22	400	402.4	14
450	452.7	15.6	11	12.2	15.34	13.8	15.3	19.11	17.2	19.1	23.64	21.5	23.8	29.19	26.7	29.5	35.76	450	452.7	15.6
500	503	17.5	12.3	13.7	19.09	15.3	17	23.57	19.1	21.2	29.16	23.9	26.4	36.02	29.7	32.8	44.18	500	503	17.5
560	563.4	19.6	13.7	15.2	23.78	17.2	19.1	29.66	21.4	23.7	36.55	26.7	29.5	45.08	33.2	36.7	55.34	560	563.4	19.6
630	633.8	22.1	15.4	17.1	30.08	19.3	21.4	37.42	24.1	26.7	46.32	30	33.1	56.94	37.4	41.3	70.10	630	633.8	22.1
710	716.4	24.9	17.4	19.3	38.28	21.8	24.1	47.55	27.2	30.1	58.87	33.9	37.4	72.50	42.1	46.6	88.94	710	716.4	24.9
800	807.2	28	19.6	21.7	48.54	24.5	27.1	60.24	30.6	33.8	74.56	38.1	42.1	91.90	47.4	52.3	112.78	800	807.2	28
900	908.1	31.5	22	24.3	61.22	27.6	30.5	76.31	34.4	38.3	94.68	42.9	47.3	116.28	53.3	58.8	142.66	900	908.1	31.5
1000	1009	35	24.5	27.1	75.80	30.6	33.5	93.56	38.2	42.2	116.37	47.7	52.6	143.66	59.3	65.4	176.32	1000	1009	35

DIAMETER		OVALITY	PN 12.5 SDR 13.6		0.960	PN 16 SDR 11		0.960	PN 20 SDR 9		0.960	PN 25 SDR 7.4		0.960	PN 34 SDR 6		0.960	DIAMETER		OVALITY
MIN	MAX	MAX	MIN	MAX	KG/M	MIN	MAX	KG/M	MIN	MAX	KG/M	MIN	MAX	KG/M	MIN	MAX	KG/M	MIN	MAX	MAX
110	110.7	2.2	8.1	9.1	2.63	10	11.1	3.16	12.3	13.7	3.80	15.1	16.8	4.52	18.3	20.3	5.28	110	110.7	2.2
125	125.8	2.5	9.2	10.3	3.39	11.4	12.7	4.10	14	15.1	4.92	17.1	19	5.82	20.8	23	6.81	125	125.8	2.5
140	140.9	2.8	10.3	11.5	4.24	12.7	14.1	5.12	15.7	17.4	6.16	19.2	21.3	7.31	23.3	25.8	8.55	140	140.9	2.8
160	161	3.2	11.8	13.1	5.54	14.6	16.2	6.72	17.9	19.8	8.02	21.9	24.2	9.52	26.6	29.4	11.15	160	161	3.2
180	181.1	3.6	13.3	14.8	7.03	16.4	18.2	8.49	20.1	22.3	10.15	24.6	27.2	12.04	29.9	33	14.09	180	181.1	3.6
200	201.2	4	14.7	16.3	8.62	18.2	20.2	10.47	22.4	24.8	12.56	27.4	30.3	14.89	33.2	36.7	17.40	200	201.2	4
225	226.4	4.5	16.6	18.4	10.95	20.5	22.7	13.25	25.2	27.9	15.89	30.8	34	18.82	37.4	41.3	22.03	225	226.4	4.5
250	251.5	5	18.4	20.4	13.49	22.7	25.1	16.30	27.9	30.8	19.53	34.2	37.8	23.23	41.5	45.8	27.17	250	251.5	5
280	281.7	9.8	20.6	22.8	16.90	25.4	28.1	20.43	31.3	34.6	24.55	38.3	42.3	29.13	46.5	51.3	34.08	280	281.7	9.8
315	316.9	11.1	23.2	25.7	21.43	28.6	31.6	25.86	35.2	38.9	31.06	43.1	47.6	36.88	52.3	57.7	43.13	315	316.9	11.1
355	357.2	12.5	26.1	28.9	27.16	32.2	35.6	32.83	39.7	43.8	39.44	48.5	53.5	46.76	59	65	54.79	355	357.2	12.5
400	402.4	14	29.4	32.5	34.45	36.3	40.1	41.68	44.7	49.3	50.04	54.7	60.3	59.39	-	-	-	400	402.4	14
450	452.7	15.6	33.1	36.6	43.63	40.9	45.1	52.78	50.3	55.5	63.35	61.5	67.8	75.14	-	-	-	450	452.7	15.6
500	503	17.5	36.8	40.6	53.84	45.4	50.1	65.13	55.8	61.5	78.07	-	-	-	-	-	-	500	503	17.5
560	563.4	19.6	41.2	45.5	67.55	50.8	56	81.59	62.5	68.9	97.94	-	-	-	-	-	-	560	563.4	19.6
630	633.8	22.1	46.3	51.1	85.38	57.2	63.1	103.38	70.3	77.5	123.94	-	-	-	-	-	-	630	633.8	22.1
710	716.4	24.9	52.2	57.6	108.47	64.5	71.1	131.32	79.3	87.4	157.53	-	-	-	-	-	-	710	716.4	24.9
800	807.2	28	58.8	64.8	137.59	72.6	80	166.53	89.3	98.4	199.87	-	-	-	-	-	-	800	807.2	28
900	908.1	31.5	66.2	73	174.31	81.7	90	210.80	-	-	-	-	-	-	-	-	-	900	908.1	31.5
1000	1009	35	72.5	79.9	212.30	90.2	99.4	258.81	-	-	-	-	-	-	-	-	-	1000	1009	35



[www.gradcosa.co.za](http://www.gradcosa.co.za)

# DESIGN CONSIDERATION

The flow charts given here have each been calculated for a particular SDR and can therefore be applied various pressure classes depending on the material designation stress

Only sizes covered by SANS/ISO 4427 have been included in these charts. The table below gives the PN classes (pressure in bar) covered by each SDR.

The nomogram on the right provides a guide to friction losses that can be expected when using clean HDPE pressure pipes with clean water at 20 °C. No account has been taken of any possible fittings in line.

SDR	PE 100
33	-----
26	6.3
21	8
17	10
13.6	12.5
11	16
9	20
7.4	25

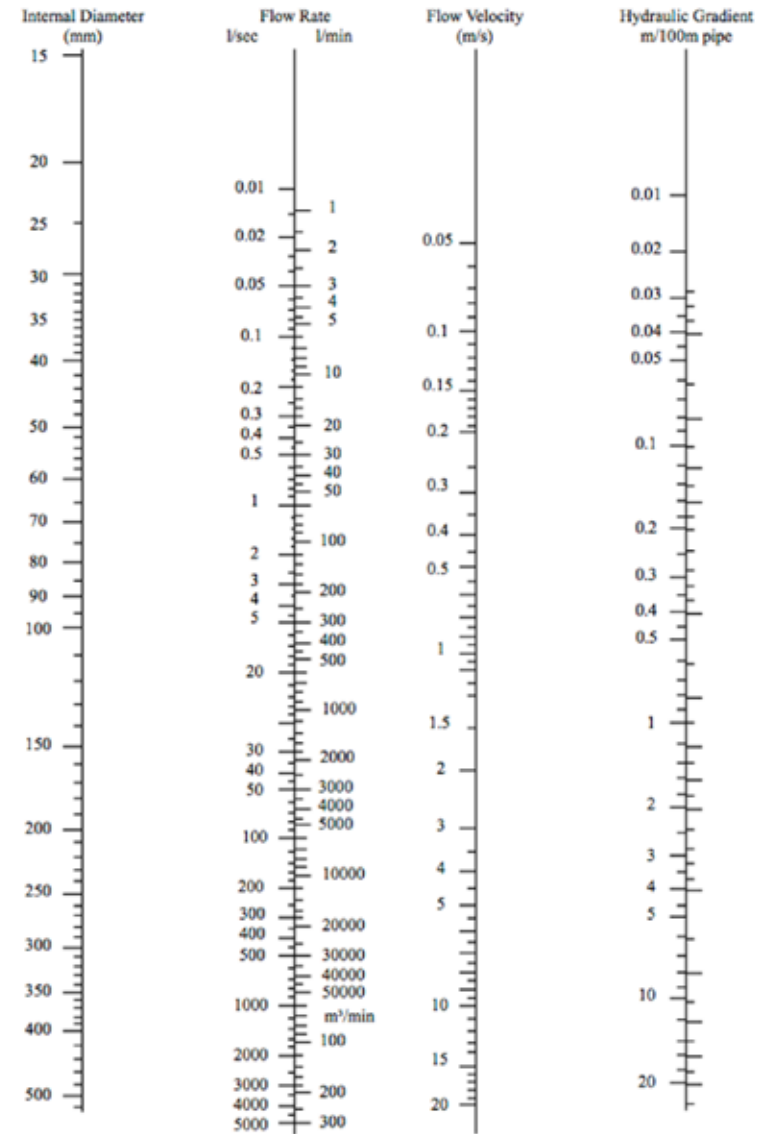
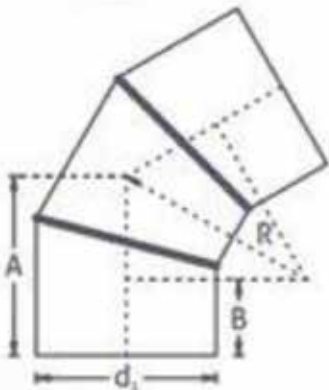
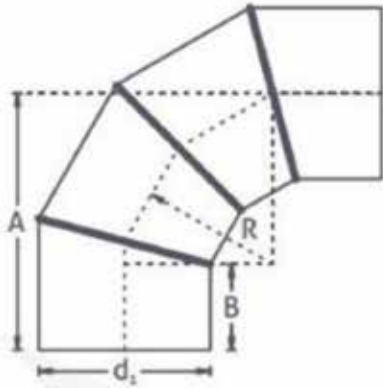

Diagram for water at 20 °C

Approximate values only



TEMPERATURE (°C)	OPERATION PERIOD (YEARS)	DIAMETER WALL THICKNESS RELATION SDR						
		41	33	26	17	11	7.4	6
		PIPE SERIES S						
		20	16	12.5	8.3	5	3.2	2.5
		PN						
		PERMISSIBLE COMPONENT OPERATING PRESSURE 1) 2) 3) [BAR]						
10 °C	1	4.5	5.7	7.2	10.9	18.1	28.7	36.1
	5	4.2	5.2	6.6	10	16.6	26.3	33.1
	10	4	5	6.4	9.6	16	25.3	31.8
	25	3.8	4.8	6.1	9.2	15.2	24.1	30.4
	50	3.7	4.6	5.8	8.8	14.6	23.1	29.1
	100	3.5	4.5	5.6	8.5	14.1	22.3	28.1
20 °C	1	3.9	4.9	6.2	9.4	15.6	24.7	31.1
	5	6.6	4.5	5.7	8.6	14.2	22.5	28.4
	10	3.4	4.3	5.5	8.3	13.7	21.7	27.4
	25	3.3	4.1	5.2	7.8	13	20.6	25.9
	50	3.1	3.9	5	7.5	12.5	19.8	24.9
	100	3	3.8	4.8	7.2	12	19	23.9
30 °C	1	3.4	4.2	5.3	8	13.3	21.1	26.6
	5	3	3.8	4.8	7.3	12.1	19.2	24.1
	10	2.9	3.7	4.6	7	11.6	18.4	23.1
	25	2.8	3.5	4.4	6.6	11	17.4	21.9
	50	2.6	3.3	4.2	6.3	10.5	16.6	20.9
40 °C	1	3.3	4.1	5.2	7.8	13	20.6	25.9
	5	2.9	3.7	4.7	7	11.7	18.5	23.3
	10	2.8	3.5	4.4	6.7	11.1	17.6	22.2
	25	2.6	3.3	4.2	6.3	10.5	16.7	21
	50	2.5	3.2	4	6	10	15.8	19.9
50 °C	1	2.7	3.4	4.3	6.5	10.8	17.2	21.6
	5	2.4	3.1	3.9	5.8	9.7	15.4	19.3
	10	2.3	2.9	3.7	5.6	9.3	14.7	18.5
	25	2.2	2.7	3.5	5.2	8.7	13.8	17.3
	50	2.1	2.6	3.3	5	8.3	13.1	16.5
60 °C	1	2.5	3.3	4	6	1.1	15.9	20.1
	5	2.2	2.8	3.6	5.4	8.9	14.2	17.8
	10	2.2	2.7	3.4	5.2	8.6	13.7	17.2
	25	2	2.5	3.2	4.8	8	12.6	15.9
	50	1.9	2.4	3	4.5	7.5	11.9	15



## FITTINGS

90 SEGMENTED BEND | 45 SEGMENTED BENDS

DIAMETER (d)	RADIUS (r)	90°(A)	45°(A)
50	75	220	220
63	93	280	280
75	113	330	330
90	135	400	400
110	165	370	370
125	188	400	400
140	210	430	430
160	240	470	470
180	270	510	510
200	300	550	550
225	338	600	600
250	375	650	650
280	420	710	710
315	472	620	620
355	532	680	680
400	600	760	760
450	675	1300	900
500	750	1400	900
560	840	1150	950
630	945	1300	1100
710	1065	1450	1250
800	1200	1500	1300

## FITTINGS

### SEGMENT T-PIECES

OD (d)	A	B
50	150	300
63	150	300
75	400	800
90	400	800
110	400	800
125	400	800
140	400	800
160	400	800
180	450	900
200	450	900
225	450	900
250	450	900
280	450	900
315	650	1300
355	650	1300
400	650	1300
450	850	1700
500	850	1700
560	900	1800
630	900	1800
710	1150	2300
800	1150	2300

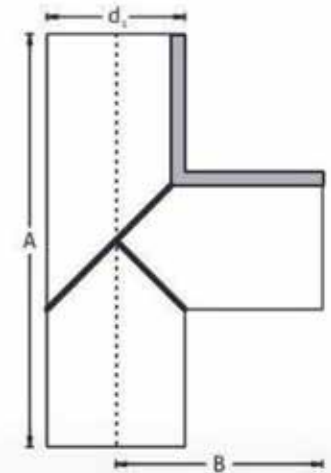

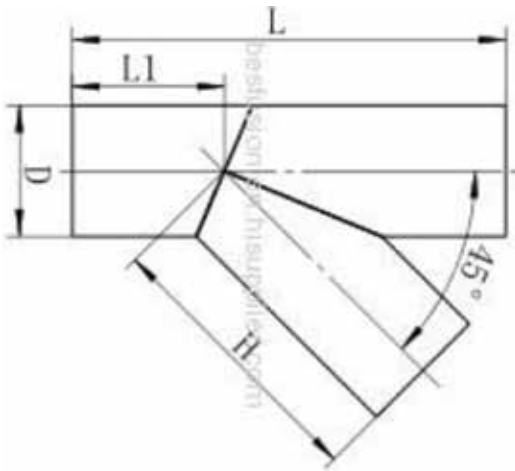

## FITTINGS

### SEGMENTED LATERALS

OD	H	L1	L
50	200	150	400
63	200	150	400
75	475	370	950
90	475	370	950
110	475	370	950
125	475	370	950
140	475	370	950
160	475	370	950
180	875	530	1350
200	875	530	1350
225	875	530	1350
250	875	530	1350
280	900	700	1800
315	900	700	1800
355	900	700	1800
400	900	700	1800
450	1100	870	2200
500	1100	870	2200
560	1200	950	2400
630	1200	950	2400
710	1500	1200	3000
800	1500	1200	3000

## FITTINGS

### SEAMLESS LONG RADIUS BENDS

OD (d)	PLAIN ENDED			FLANGED		TAK & VICTAULIC	
	R	45°L	90°L	45°L	90°L	45°L	90°L
110	330	345	535	400	690	400	590
125	375	360	580	420	640	415	635
140	420	380	625	440	685	435	680
160	480	405	685	475	755	460	740
180	540	430	745	500	815	515	830
200	600	455	805	525	875	540	890
225	675	485	880	565	960	570	965
250	750	515	955	595	1035	600	1040
280	840	555	1045	637	1125	-	-
315	945	585	1150	675	1240	-	-
355	1065	645	1270	735	1360	-	-
400	1200	705	1405	805	1505	-	-
450	1350	765	1555	865	1655	-	-
500	1500	830	1705	930	1805	-	-



90° Plain

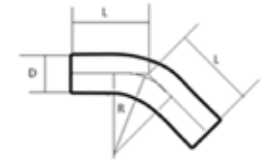

45° Plain

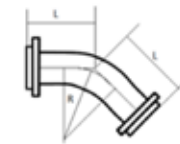

90° Plain

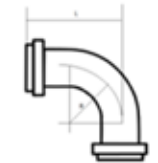

45° Tak and Victaulic Ends

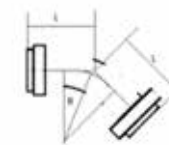

90° Tak and Victaulic Ends



90° Flanged

## INJECTION MOULDED FITTINGS STUB FLANGES (BUTT-WELD)

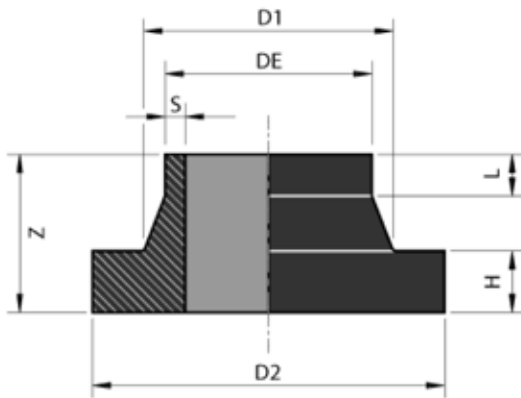

DE	SDR 17		SDR 11		D <sub>1</sub>	D <sub>2</sub>	Z
	H	L	H	L			
20	-	-	7	30	37	45	50
25	-	-	9	28	33	58	50
32	-	-	10	27	40	68	50
40	11	24	11	24	50	78	50
50	12	23	12	23	61	88	50
63	14	18	14	18	75	102	50
75	16	14	16	14	89	122	50
90	17	43	17	35	105	138	80
110	18	37	18	37	125	158	80
125	18	42	25	35	132	158	80
140	18	34	25	27	155	188	80
160	18	34	25	27	175	212	80
180	20	30	30	20	181	212	80
200	24	36	32	28	232	268	100
225	24	46	32	38	235	268	100
250	25	35	35	25	285	320	100
280	25	45	35	35	291	320	100
315	25	35	35	25	335	370	100
355	30	30	30	20	373	430	120
400	33	42	42	29	427	482	120
450	46	14	14	10	514	585	120
500	46	24	24	10	530	585	120
560	50	10	10	20	615	685	120
630	50	30	30	20	642	685	120

DE	SDR 33				
	H	L	D <sub>1</sub>	D <sub>2</sub>	Z
110	18	37	125	158	80
125	18	42	132	158	80
140	18	34	155	188	80
160	18	34	175	212	80
180	18	32	181	212	80
200	18	42	232	268	100
225	18	52	235	268	100
250	20	40	285	320	100
280	20	50	291	320	100
315	20	40	335	370	100
355	23	57	373	430	120
400	26	49	427	482	120
450	33	27	514	585	120
500	33	37	530	585	120
560	35	25	615	685	120
630	35	45	642	685	120

## INJECTION MOULDED FITTINGS

### TEES 90° (BUTT-WELD)

DE	SDR 17 & SDR 11		
	L	Z	I
20	50	25	8
25	60	30	10
32	72	36	12
40	88	44	16
50	116	58	21
63	146	73	24
75	170	85	28
90	200	100	23
110	240	120	43
125	250	125	26
140	280	140	32
160	320	160	40
180	390	195	73
200	430	215	70
225	480	240	72
250	550	275	86
280	620	310	105
315	700	350	111
355	658	330	95
400	682	345	104
450	890	450	130
500	890	450	130

DE	SDR 33		
	L	Z	I
110	249	121	50
125	262	132	47
140	293	145	48
160	318	160	55
180	356	175	59
200	385	194	55
225	442	212	59
250	465	232	70
280	536	268	8
315	530	263	75
355	658	330	95
400	690	345	104
450	890	450	130
500	895	450	130

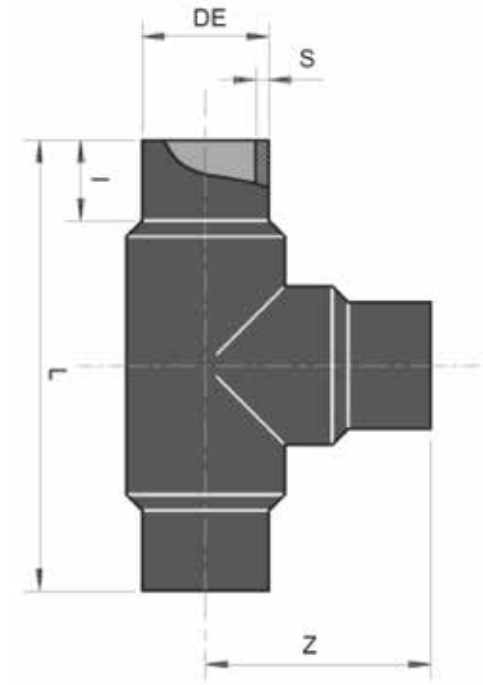

# INJECTION MOULDED FITTINGS

ELBOW 90° (BUTT-WELD)

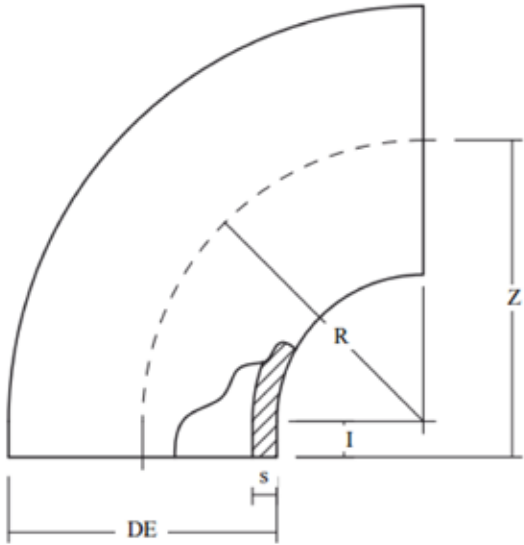

## SDR 33

DE	Z	I	R
20	25	5	20
25	30	5	25
32	36	4	32
40	43	3	40
50	51	1	50
63	64	1	63
75	85	10	75
90	100	10	90
110	120	10	110
125	140	15	125
140	155	15	140
160	175	15	160
180	195	15	180
200	215	15	200
225	245	20	225
250	275	25	250
280	310	30	280
315	350	35	315
355	340	40	300
400	345	45	300
450	350	50	400
500	350	50	400

## SDR 17 & SDR 11

DE	Z	I	R
110	120	10	110
125	140	15	125
140	150	10	140
160	180	25	155
180	200	25	175
200	220	23	197
225	250	20	230
250	290	25	265
280	290	10	280
315	340	40	300
355	340	40	300
400	345	45	300
450	450	50	400
500	450	50	400

## INJECTION MOULDED FITTINGS

### REDUCER - CONCENTRIC CONTINUED (BUTT-WELD)

SDR 17 & SDR 11				
DE <sub>1</sub>	DE <sub>2</sub>	L	l <sub>1</sub>	l <sub>2</sub>
355	200	183	30	20
355	225	170	34	28
355	250	125	30	22
355	280	100	32	23
355	315	72	30	21
400	225	196	25	20
400	250	175	25	20
400	280	148	25	20
400	315	118	25	20
400	355	84	25	20
450	280	192	25	20
450	315	161	25	20
450	355	127	25	20
450	400	88	25	20
500	280	235	25	20
500	315	205	25	20
500	355	170	25	20
500	400	131	25	20
500	450	88	25	20
560	355	222	25	20
560	400	183	25	20
560	450	140	25	20
560	500	97	25	20
630	355	283	25	20
630	400	244	25	20
630	450	200	25	20
630	500	157	25	20
630	560	105	25	20

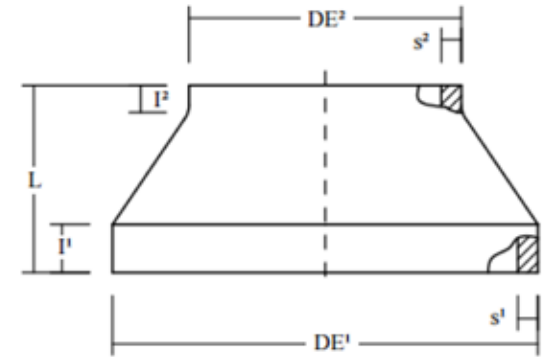

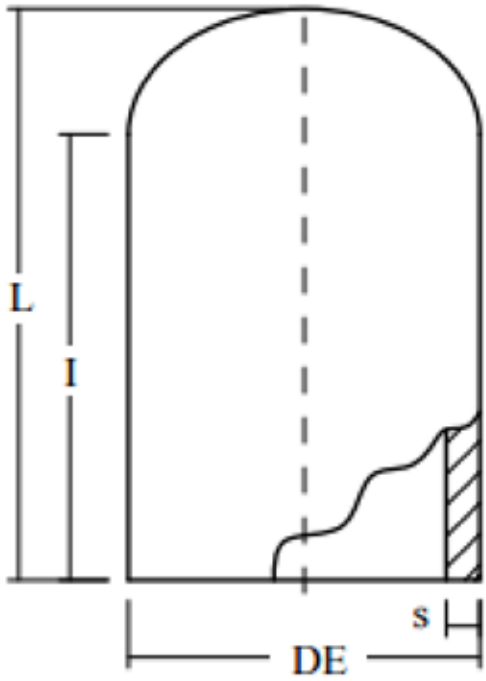

## INJECTION MOULDED FITTINGS

END CAPS- (BUTT-WELD)

DE	L	I
20	45	35
25	52	40
32	58	45
40	67	50
50	75	55
63	85	62
75	82	66
90	110	78
110	125	88
125	55	25
140	65	30
160	80	40
180	90	47
200	100	50
225	110	60



## FLANGES

BS 10 TABLE D						
PIPE SIZE	DIMENSIONS - mm				BOLTS	
	D	D <sub>1</sub>	B	PCD	NO.	SIZE
20	95.5	30	8	66.7	4	M12
25	101.6	38	8	73	4	M12
32	114.3	45	8	82.6	4	M12
40	120.6	52	10	87.3	4	M12
50	133.3	63	10	98.4	4	M12
63	152.4	74	10	114.3	4	M16
75	165.1	86	10	127	4	M16
90	184.1	103	12	146	4	M16
110	215.9	128	15	177.8	4	M16
125	254	135	15	209.6	8	M16
140	254	158	15	209.6	8	M16
160	279.4	188	15	235	8	M16
180	285	188	15	235	8	M16
200	336.6	236	16	292	8	M16
225	369	236	16	323.9	8	M16
250	406.4	279	16	355.6	8	M20
280	406.4	292	20	355.6	8	M20
315	457.2	350	20	406.4	12	M20
355	527.1	367	23	469.9	12	M24
400	577.9	430	23	520.7	12	M24
450	641.4	476	25	584.2	12	M24
500	704.9	533	25	641.4	16	M24
560	762	592	30	698	16	M24
630	825.5	662	30	755.7	16	M24

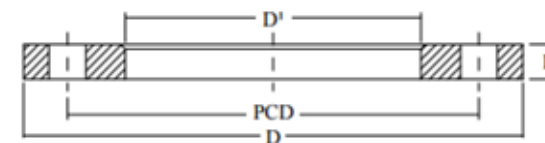

# FLANGES

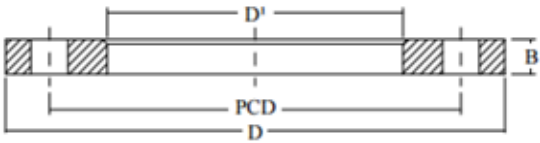

PIPE SIZE	SABS 1123 1600/3						SABS 1123 1000/3				
	DIMENSIONS - mm				BOLTS		DIMENSIONS - mm			BOLTS	
	D	D <sub>1</sub>	B	PCD	NO.	SIZE	D	B	PCD	NO.	SIZE
20	95	30	10	65	4	M12	95	10	65	4	M12
25	105	38	10	75	4	M12	105	10	75	4	M12
32	115	45	10	85	4	M12	115	10	84	4	M12
40	140	52	12	100	4	M16	140	12	100	4	M16
50	150	63	12	110	4	M16	150	12	110	4	M16
63	165	74	12	125	4	M16	165	12	125	4	M16
75	185	86	12	145	4	M16	185	12	145	4	M16
90	200	103	12	160	8	M16	200	12	160	8	M16
110	220	128	15	180	8	M16	220	15	180	8	M16
125	250	135	15	210	8	M16	250	15	210	8	M16
140	250	158	15	210	8	M16	250	15	210	8	M16
160	285	188	20	240	8	M20	285	20	240	8	M20
180	285	188	20	240	8	M20	285	20	240	8	M20
200	340	236	20	295	12	M20	340	20	295	8	M20
225	340	236	20	295	12	M20	340	20	295	8	M20
250	405	279	25	355	12	M24	395	25	350	12	M20
280	405	292	25	355	12	M24	395	25	350	12	M20
315	460	350	25	410	12	M24	445	25	400	12	M20
355	520	367	25	470	16	M24	506	25	460	16	M20
400	580	430	30	525	16	M24	565	30	515	16	M24
450	640	476	30	585	20	M24	615	30	565	20	M24
500	715	533	30	650	20	M30	670	30	620	20	M24
560	775	592	36	710	20	M30	730	35	675	20	M24
630	840	662	36	770	20	M30	780	38	725	20	M24



[www.gradcosa.co.za](http://www.gradcosa.co.za)

# QUALITY CONTROL

<b>MELT MASS-FLOW RATE MFR FOR PE 100</b>	<b>CHANGE OF MFR BY PROCESSING ±20 %</b>	<b>LOAD TEST TEMPERATURE TIME NUMBER OF TEST PIECES</b>	<b>5.0KG 190 °C 10 MIN ACCORDING TO ISO 1133</b>	<b>ISO 1133:2005 CONDITION D</b>
---	--	---	--	--------------------------------------

- Melt flow rate (MFR)
  - Reference Test: ISO 1133
  - Standard Value: 0.25-0.35 change in MFR
- Value caused by processing, between the measured value for material from the pipe and the measured value for the compound, must not be greater than 20%.



<b>LONGITUDINAL REVERSION</b>	<b>≤ 3% NO EFFECT ON SURFACE</b>	<b>SHAPE AND NUMBER OF TEST PIECES C TEST TEMPERATURE TIME</b>	<b>ACCORDING TO ISO 2505 110± 2 °C MIN SEE ISO 2505</b>	<b>ISO 2505</b>
-----------------------------------	--	--	---	-----------------

- Longitudinal reversion (shrinkage)
- Reference Test: ISO 2505-1
- Standard value: Longitudinal reversion (shrinking) shall ≤3%

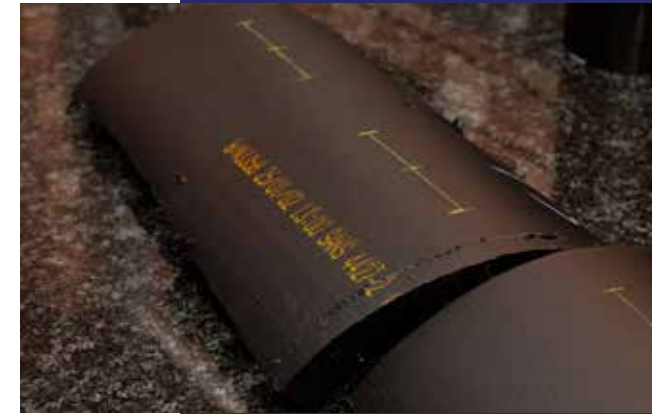

<b>ELONGATION AT BREAK FOR E ≤ 12 MM</b>	<b>≥ 350%</b>	<b>TEST PIECE SHAPE TEST SPEED NUMBER OF TEST PIECES b</b>	<b>TYPE 1 a 25MM/MIN ACCORDING TO ISO 6259</b>	<b>ISO 6259-1 ISO 6259-3</b>
--	---------------	--	--	----------------------------------

- Tensile Testing
- Reference Test: ISO 6259
- Standard value: Elongation at break must be ≥350%



TEST	REQUIREMENT	TEST METHOD
<b>OXIDATION INDUCTION TIME</b>	<b>≥ 20 MIN</b>	<b>ISO 11357-6 2002</b>
<b>HYDROSTATIC STRENGTH AT 20° / 80°</b>	<b>NO FAILURE ON ANY TEST PIECE DURING TEST PERIOD</b>	<b>ISO 1167-1 ISO 1167-2</b>

# CERTIFICATIONS & APPROVALS



## Certificate of Registration

This is to certify that the Quality Management System of

**GRADCO SA**

Registration No. 1999/026872/07 and located at Graspan Road, Middelburg

Has been assessed and verified to fulfil the requirements of

**ISO 9001:2015**

SCOPE The manufacturing of High-Density Polyethylene (HDPE) piping.

CLIENT CODE GRA004

CERTIFICATE NO. 343

ISSUE NO. 5

DATE OF INITIAL CERTIFICATION 07 October 2020

DATE OF ISSUE 04 October 2024

VALID UNTIL 06 October 2020

*\*Subject to the satisfactory operation of the management system as determined by the annual surveillance audits*

AUTHORISED BY

Managing Director

**JCA AUDITORS**  
TRUST AND INTEGRITY. OUR SOLUTION™

+27 87 880 312 | info@jcauditors.com | www.jcauditors.com



*\*To verify this certificate please scan the QR code*



## Broad-Based Black Economic Empowerment Verification Certificate

**GRADCO SOUTH AFRICA (PTY) LTD**

Certificate Number: 01/B-BBEE/2024/00475/QSE

Registration Number: 1999/026872/07  
VAT Number: 4670198854  
Head Office Location: Graspan Road  
Farm Rietfontein 286/S  
Middelburg  
Mpumalanga, 1050

Verification Standard Applied: Amended Construction Sector Code of Good Practice - Contractor  
Issue of the Rating Standard Applied: Section 9 of the B-BBEE Amendment Act 46 of 2013  
Scorecard Applied: Qualifying Small Enterprise with Turnover >R10m & >R50m

**B-BBEE Level: A level THREE contributor to B-BBEE**

**B-BBEE Procurement Recognition Level: 110%**

**Financial Year Rated: 2024/06/30**

Element	Element weighting	Score
Skills Development	24	0.00
Skills Development Discount Applied		Yes
Skills Development Enhancement Applied		No
Enterprise and Supplier Development	29	0.00
Enterprise and Supplier Development Enhancement Applied		No

Empowering Supplier	Yes	Black Ownership	51.10%
Designated Group Supplier	No	Black Female Ownership	0.00%
Modified Flow Through Applied	No	Black Designated Group Percentage	0.00%
Exclusion Principle Applied	No	Black Youth Percentage	0.00%
Discounting Principle Applied	Yes	Black Disabled Percentage	0.00%
Participated in Y.E.S Initiative	No	Black Unemployed Percentage	0.00%
Achieve Y.E.S Target and 2.5% Absorption	N/A	Black People Living in Rural Areas Percentage	0.00%
Achieve 1.5 x Y.E.S Target and 5% Absorption	N/A	Black Military Veterans Percentage	0.00%
Achieve Double Y.E.S Target and 5% Absorption	N/A	Black New Entrant Percentage	51.10%

This verification certificate and verification report is based on information provided to Amax BEE Verifications (Pty) Ltd and represent an independent opinion based on the verification and analysis completed by Amax BEE Verifications (Pty) Ltd. The calculation of the scores has been determined in accordance with the Amended Construction Sector Code of Good Practice - Contractor as Gazetted. Gazettes Nos 41287, 41866, 41975 & 42496 where applicable

Erik Botha (Technical Signatory)  
For Amax BEE Verifications (Pty) Ltd  
tel: 012 546 7248 | fax: 086 672 5709  
260 Jack Hindon Street | Pretoria North | 0182  
PO Box 16949 | Pretoria North | 0116

Date of issue: 24 October 2024  
Re-Issue Date: N/A  
Expiry date: 23 October 2025  
Period of validity: 12 Months



# CERTIFICATIONS & APPROVALS



South African Technical Auditing  
Services Pty Ltd  
(ISO/IEC 17065 : Product Certification)

## CERTIFICATE

No: 182.1/4

This is to certify that:

**GRADCO SOUTH AFRICA (PTY) LTD T/A  
GRADCO SA**

Company registration No 1999/026872/07

is hereby granted permission to apply the above logo to  
plastic products EAC/IAF 14 NACE 22,  
manufactured and in compliance with

**SANS 4427-2**

as described in schedule MS25 of this certificate.

*PL Posthumus*  
MANAGING DIRECTOR

DATE ISSUED: 7 April 2025  
EXPIRY DATE: 6 April 2028



C25

MS57.3



South African Technical Auditing  
Services Pty Ltd  
(ISO/IEC 17065 : Product Certification)

## CERTIFICATE

No: 182.2/4

This is to certify that:

**GRADCO SOUTH AFRICA (PTY) LTD T/A  
GRADCO SA**

Company registration No 1999/026872/07

is hereby granted permission to apply the above logo to  
plastic products EAC/IAF 14 NACE 22,  
manufactured and in compliance with

**DIN 8074 and DIN 8075**

as described in schedule MS25 of this certificate.

*PL Posthumus*  
MANAGING DIRECTOR

DATE ISSUED: 7 April 2025  
EXPIRY DATE: 6 April 2028



MS57.3

# CERTIFICATIONS & APPROVALS





+27 (0) 13 241 7977/8/9  
reception@gradco.co.za  
www.gradcosa.co.za

Graspan Road,  
Rietfontein Farm Industrial Area,  
Golfsig, Middelburg,  
1050

**GRADCO SA**  
PERFECTION IN PLASTIC PIPING & ENGINEERING